

Lösungen der Test units aus

TECHNISCHES ENGLISCH

Berufliche Situationen und Aufgaben
aus der Berufsschule und Lehrwerkstatt

Mit Grammatikinhalten

Test unit for Measuring technique *mit Lösungen*

Übungseinheit zur Messtechnik

You are an **exchange student** in Manchester, Great Britain, and work at a metal processing company for three weeks. Your **instructor** has given you a demonstration copy of a **key fob** and forwarded you the order to produce one of it.

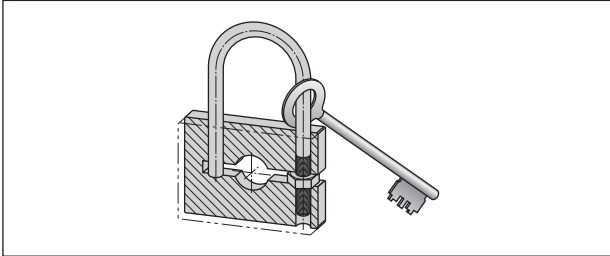

You have milled and drilled the steel blocks and you have bent the brackets. So all of the parts are on your workbench in front of you.

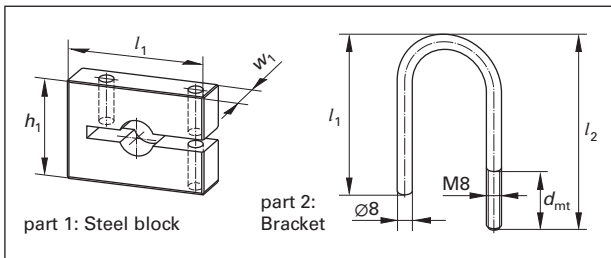

1. In order to **check all relevant dimensions** and to **test if all parts can be assembled** you have to **make an inspection plan** of the steel block (part 1) and the bracket (part 2).

The tolerances are according to **General tolerances, class m**. (Use the Metal Trades Handbook for looking up the tolerances)

Inspection plan Key Fob part 1: steel block			
Identification number: 18012		Drawing number: 24107	
Designation: steel block		Inspection plan no.: 81	
Serial No.	Inspection characteristic	Tolerance GT/m	Measuring instrument
1	length $l_1 = 65$ mm	± 0.3	<i>Calliper</i>
2	width $w_1 = 12$ mm	± 0.2	<i>Calliper</i>
3	height $h_1 = 40$ mm	± 0.3	<i>Calliper</i>
4	groove, length $l_2 = 50$ mm	± 0.3	<i>Calliper</i>
5	groove, height $h_1 = 8$ mm	± 0.2	<i>Calliper</i>
6	internal diameter groove $d_1 = 16$ mm	± 0.2	<i>Calliper</i>
7	diameter hole $d_2 = 8.1$ mm	± 0.2	<i>Calliper</i>
8	depth of hole $d_{h2} = 12$ mm	± 0.2	<i>Calliper</i>
9	distance from center of holes $d_{h1/h2} = 40$ mm	± 0.3	<i>Calliper</i>
10	diameter hole $d_3 = 8.1$ mm	± 0.2	<i>Calliper</i>

Inspection plan Key Fob part 2: bracket			
Identification number: 18012		Drawing number: 24108	
Designation: bracket		Inspection plan no.: 82	
Serial No.	Inspection characteristic	Tolerance GT/m	Measuring instrument
1	length $l_1 = 50$ mm	± 0.3	<i>Calliper</i>
2	diameter bracket $d = 8$ mm	± 0.2	<i>Calliper</i>
3	external diameter $d_{ex} = 48$ mm	± 0.3	<i>Calliper</i>
4	length $l_2 = 65$ mm	± 0.3	<i>Calliper</i>
5	metric thread M8	± 0.2	<i>thread gauge</i>
6	depth of metric thread $d_{mt} = 20$ mm	± 0.2	<i>Calliper</i>

2. You are back in your training workshop and **present your manufactured key fob**. Your instructor would like to **display this key fob** on the special event of the open house.

Therefore he asked you to **translate the inspection plan** of the **steel block** and the **bracket** into German. Here is the beginning. Translate it completely.

Prüfplan des Schlüsselanhängers Teil 1: Stahlblock			
Identifikationsnummer: 18012		Zeichnungs Nr: 24107	
Bezeichnung: Stahlblock		Prüfplan Nr: 81	
Ldf. Nr.	Prüfmerkmal	Toleranz	Prüfmittel
1	Länge $l_1 = 50$ mm	$\pm 0,3$	<i>Messschieber</i>
2	Breite $w_1 = 12$ mm	$\pm 0,2$	<i>Messschieber</i>
3	Höhe $h_1 = 40$ mm	$\pm 0,3$	<i>Messschieber</i>
4	Nut/Länge $l_2 = 50$ mm	$\pm 0,3$	<i>Messschieber</i>
5	Nut/Höhe $h_2 = 8$ mm	$\pm 0,2$	<i>Messschieber</i>
6	Innendurchmesser der Nut $d_1 = 16$ mm	$\pm 0,2$	<i>Messschieber</i>
7	Durchmesser Bohrung 2 $d_2 = 8,1$ mm	$\pm 0,2$	<i>Messschieber</i>
8	Tiefe Bohrung 2 $d_{h2} = 12$ mm	$\pm 0,2$	<i>Messschieber</i>
9	Bohrungsabstand $d_{m/h2} = 40$ mm	$\pm 0,3$	<i>Messschieber</i>
10	Bohrung 3 $d_3 = 8,1$ mm	$\pm 0,3$	<i>Messschieber</i>

Prüfplan des Schlüsselanhängers Teil 2: Bügel			
Identifikationsnummer: 18012		Zeichnungs Nr: 24108	
Bezeichnung: Bügel		Prüfplan Nr: 82	
Ldf. Nr.	Prüfmerkmal	Toleranz ISO 2768-m	Prüfmittel
1	Länge $l_1 = 50$ mm	$\pm 0,3$	Messschieber
2	Breite $d = 8$ mm	$\pm 0,2$	<i>Messschieber</i>
3	Außendurchmesser $d_{Au} = 48$ mm	$\pm 0,3$	<i>Messschieber</i>
4	Länge $l_2 = 65$ mm	$\pm 0,3$	<i>Messschieber</i>
5	M8	$\pm 0,2$	<i>Gewindelehre</i>
6	Gewindetiefe $d_{Gew} = 20$ mm	$\pm 0,2$	<i>Messschieber</i>

3. Now check your knowledge about measuring techniques and equipment with the following crossword puzzle below.

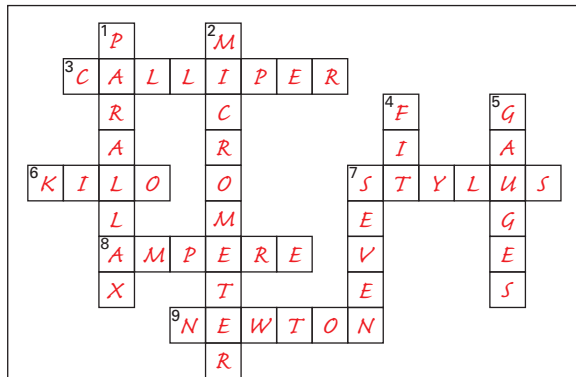

ACROSS

- 3 A general measuring device used to find out smaller distances and measured workpieces
- 6 A prefix for units for a multiple of thousand
- 7 With this instrument you can record the roughness of a surface
- 8 The most commonly used unit for electric current
- 9 The common unit for a force

DOWN

- 1 If you have an incorrect eye position when reading the scale, these errors can occur
- 2 The right instrument for very accurate measurements
- 4 A relationship between a bore and a matching shaft is called:
- 5 The measuring devices represent certain dimensions or geometric forms e.g. radii
- 7 Number of base quantities in technology

Test unit for Quality management *mit Lösungen*

Übungseinheit zur Qualitätssicherung

1. 10-minutes quiz to check your knowledge about quality management!

- a) What is meant by the expression "quality"?
It is a certain attribute or characteristic of a product.
- b) Why is quality management essential for companies?
In order to be successful and competitive on the market.
- c) In which areas of a company is quality management necessary? Mention 3 different ones.
Quality improvement: production quality planning: production planning quality control: inspection
- d) What is the 1-10-100 rule? Name it.
When a product moves through a production sequence, the cost of correcting an error multiplies by 10 from stage to stage.

- e) Which quality tools are used in industry?
Defect chart, histogram, quality control chart, Pareto chart, cause-and-effect diagram
- f) Explain Pareto's principle!
It states that 80 % of consequences come from 20 % of the causes.
- g) What is the content of a tally sheet?
It shows the data about the frequency of occurrence of a value.
- h) What can you do with it?
It is needed to draw a histogram.
- i) What is the name of a common bar chart showing the frequency of data within a certain range?
histogram
- j) Which values can be calculated from this chart?
range R, arithmetic mean \bar{x} , median \tilde{x} , standard deviation s

2. Your company Metallix produces shafts for E-bikes by turning. You receive a raw data list of a sample of 56 different measurements of the nominal length of the shaft $l = 56 \text{ mm} \pm 0.2 \text{ mm}$.

Measured value no.	Measured values in mm									
1...10	39.89	40.03	40.10	40.02	40.09	39.97	40.04	39.99	39.98	40.10
11...20	40.00	39.99	40.00	40.04	40.00	40.01	40.02	40.01	40.03	40.07
21...30	40.02	40.02	40.07	40.02	40.02	40.14	40.07	40.03	40.03	39.94
31...40	40.03	40.06	40.03	40.04	40.07	40.04	40.04	40.00	40.04	40.05
41...50	40.05	40.05	40.06	40.05	40.06	40.05	39.96	40.06	40.03	40.03
51...56	40.07	40.03	40.08	40.08	40.10	40.02				

Calculate the statistical characteristics of the data series and draw a histogram according to the calculation scheme of the adjacent form.

- a) Enlarge the task on the right to DIN A4 size. To do this, use the print function in the top line of the computer keyboard, for example.
- b) Calculate the statistical parameters using the formulas given and enter them in the calculation scheme.
- c) Calculate the characteristic values for creating a histogram.
- d) Create the data collection list (tally sheet).
- e) Draw the histograms n_j and h_j in the form.

Evaluation form

evaluation: sample:	part no: 1234567	measuring scope: n = 56	charac-teristics: length l	inspected dimension: 40 ± 0.2 mm	measuring device: digital micrometer	responsible employee: LR	date:
---------------------	------------------	-------------------------	----------------------------	----------------------------------	--------------------------------------	--------------------------	-------

Measured value no.	Measured values in mm									
1...10	39.89	40.03	40.10	40.02	40.09	39.97	40.04	39.99	39.98	40.10
11...20	40.00	39.99	40.00	40.04	40.00	40.01	40.02	40.01	40.03	40.07
21...30	40.02	40.02	40.07	40.02	40.02	40.14	40.07	40.03	40.03	39.94
31...40	40.03	40.06	40.03	40.04	40.07	40.04	40.04	40.00	40.04	40.05
41...50	40.05	40.05	40.06	40.05	40.06	40.05	39.96	40.06	40.03	40.03
51...56	40.07	40.03	40.08	40.08	40.10	40.02				

Data and calculations

nominal value	N =
upper shaft tolerance	Ao =
lower shaft tolerance	Au =
tolerance	T =
shaft maximal dimension	G _{JS} =
shaft minimum dimension	G _{LS} =
centre of tolerance	M =

Statistical characteristics

number of measured values	n =
---------------------------	-----

Limit values

maximum value	x _{max} =
minimum value	x _{min} =

Range of variance R = x_{max} - x_{min}

range	R =
-------	-----

Median value

median value	\tilde{x} =
--------------	---------------

Mean value

mean value	\bar{x} =
------------	-------------

Creating a histogram:

Calculations

$$k = \sqrt{n}; b = \frac{R}{k}; x_w = \frac{n_j}{n}$$

number of classes:	k ≈	rounded:
class interval:	b ≈	rounded:
frequency of a class interval:	x _w	

Tally sheet $h_j = \frac{n_j}{n}$

class no.	measured value	tally list	n _j	h _j in %
1	≥			
2	≤			
3				
4				
5				
6				
7				
8				
9				

Histogram

a) **Evaluation form**

evaluation: sample:	part no: 1234567	measuring scope: $n = 56$	charac- teristics: length l	inspected dimension: $40 \pm 0,2 \text{ mm}$		measuring device: digital micrometer	responsible employee: LR	date:
------------------------	---------------------	---------------------------------	-------------------------------------	--	--	---	--------------------------------	-------

Measured value no.	Measured values in mm									
1...10	39.89	40.03	40.10	40.02	40.09	39.97	40.04	39.99	39.98	40.10
11...20	40.00	39.99	40.00	40.04	40.00	40.01	40.02	40.01	40.03	40.07
21...30	40.02	40.02	40.07	40.02	40.02	40.14	40.07	40.03	40.03	39.94
31...40	40.03	40.06	40.03	40.04	40.07	40.04	40.04	40.00	40.04	40.05
41...50	40.05	40.05	40.06	40.05	40.06	40.05	39.96	40.06	40.03	40.03
51...56	40.07	40.03	40.08	40.08	40.10	40.02				

b) **Data and calculations**

nominal value	$N =$	40.0
upper shaft tolerance	$A_o =$	0.2
lower shaft tolerance	$A_u =$	-0.2
tolerance	$T =$	0.4
shaft maximal dimension	$G_{US} =$	40.2
shaft minimum dimension	$G_{IS} =$	39.8
centre of tolerance	$M =$	40.0

Statistical characteristics

number of measured values	$n =$	56
---------------------------	-------	----

Limit values

maximum value	$x_{\max} =$	40.14
minimum value	$x_{\min} =$	39.94

Range of variance $R = x_{\max} - x_{\min}$

range	$R =$	0.20
-------	-------	------

Median value

median value	$\tilde{x} =$	40.03
--------------	---------------	-------

Mean value

$$\bar{x} = \frac{x_1 + x_2 + x_3 + \dots + x_n}{n}$$

mean value	$\bar{x} =$	40.036
------------	-------------	--------

c) **Creating a histogram:**

Calculations

$$k = \sqrt{n}; b = \frac{R}{k}; x_w = \frac{n_c}{n}$$

number of classes:	$k =$	7.48	≈ 7
class interval:	$b =$	0.0286	≈ 0.03
frequency of a class interval	$x_w =$	0.125	

d)

Tally sheet $h_j = \frac{n_j}{n}$

class no.	measured value \geq	measured value \leq	tally list	n_j	h_j in %
1	39.94	39.97		2	3.6
2	39.97	40.00		5	8.9
3	40.00	40.03		13	23.2
4	40.03	40.06		20	35.7
5	40.06	40.09		11	19.6
6	40.09	40.12		4	7.1
7	40.12	40.15		1	1.6
8	40.15			0	0
9			Sum n	56	

e)

Histogram n_j



Histogram h_j

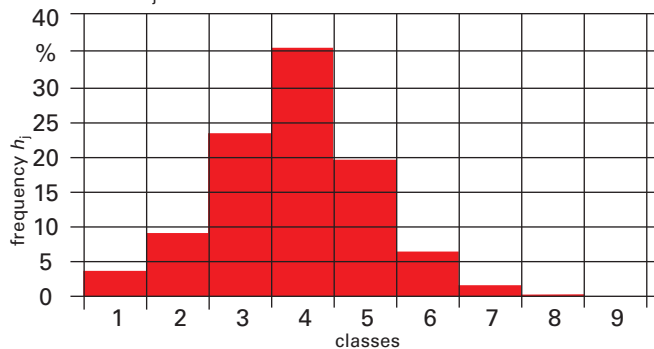

Test unit for Production engineering *mit Lösungen*

Übungseinheit zur Fertigungstechnik

1. By which manufacturing techniques could the workpiece and the components of the machine bench vice in the picture be produced?

- a) The plastic handle Turning
- b) The basis vice body Milling and drilling
- c) The workpiece Turning and drilling
- d) The stocks Milling
- e) The socket screws Turning and stamping

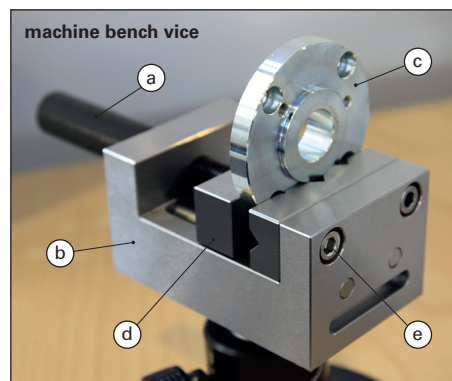

2. What semi-finished products are the components made of?

- a) The plastic handle Plastic rod
- b) The basis vice body Hot rolled square steel bar
- c) The workpiece Round steel bar
- d) The stocks Hot rolled flat bar
- e) The socket screws Hot rolled round bar

3. The workpiece (c) is made of quenched and tempered steel 18CrMo4. Determine the twist drill type and the drilling data for drilling holes of 10 mm diameter into the workpiece with a HSS drill by using your Metal Trade Handbook.

- a) Twist drill type Type N
- b) Tensile strength of the material 18CrMo4 > 900 N/mm²
- c) Cutting velocity $v_c = 20 \dots 25 \text{ m/min}$
- d) Feed of the drill $f = 0.12 \text{ mm/revolution}$

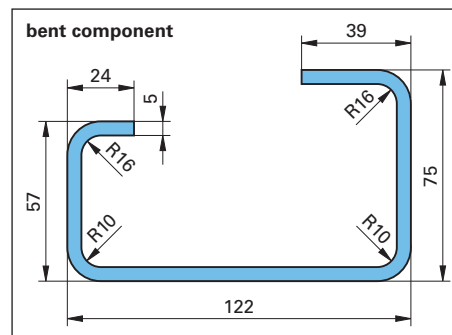

4. The bent component in the picture right hand is made of unalloyed steel sheet S275JR.

Calculate the developed length of the bent component. Use your Metal Trade Handbook.

$$L = a + b + c + d + e - 2 \cdot v(16) - 2 \cdot v(10)$$

$$L = (24 + 67 + 122 + 75 + 39 - 2 \cdot 13.3 - 2 \cdot 11.2) \text{ mm}$$

$$L = (327 - 26.6 - 22.4) \text{ mm} = 278 \text{ mm}$$

5. The picture plate beside shows different turning techniques. Match the named turning techniques to the letter of the picture plate.

- 1 Facing c
- 2 Longitudinal turning d
- 3 Parting off b
- 4 Internal turning a

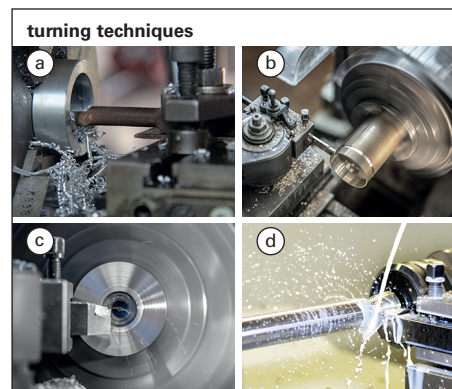

6. Project a working plan for the turning workpiece (free cutting steel, $R_m < 570 \text{ N/mm}^2$) shown besides with the following schema. Use the Metal Trade Handbook to determine the cutting data.

No.	working process	cutting data	tools
	Measure the round steel bar and place it into the chuck	-	calliper
	Facing the workpiece	$v = 250 \text{ m/min}$ $f = 0.2 \dots 0.1 \text{ mm}$ $a_p = 1 \dots 2 \text{ mm}$ $n = 1400 \text{ min}^{-1}$	squaring cutter
	Longitudinal turning	$v = 250 \text{ m/min}$ $f = 0.2 \dots 0.1 \text{ mm}$ $a_p = 1 \dots 2 \text{ mm}$	finishing cutter

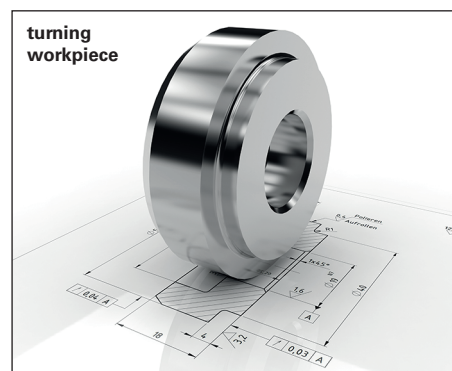

Test unit for Material engineering *mit Lösungen*

Übungseinheit zur Werkstofftechnik

1. What are the names of the objects shown in the picture and what material could they be made of?

- a) Wrench; tool steel
- b) Pipe; Copper
- c) Pipe wrench; malleable cast iron
- d) Pipe screw; brass (copper-zinc alloy)
- e) Coupling pipe section: plastic



2. Four steel materials are shown in the adjacent panel.

a) Which steel grades are shown in the picture?

- 1 Tempered steel
- 2 Free cutting steel
- 3 Tool steel
- 4 Corrosion resistant steel

b) Which of the materials shown have the designation code listed?

- 35SPb20 → ②
- C80U → ③
- X5CrNiMo17-12-2 → ④
- 34CrMo4 → ①



3. Which components and what percentages can be read from the designation code?

- a) 35SPb20: 0.35 % C, 0.20 % S, low content of Pb
- b) C80U: 0.80 % C
- c) X5CrNiMo17-12-2: 0.05 % C, 17 % Cr, 12 % Ni, 2 % Mo
- d) 34CrMo4: 0.34 % C, 1 % Cr, low content of Mo

4. The driving unit of an electric car shown in the picture has an Aluminium cast alloy housing, transmission gears made of tempered steel and copper windings of the motor.

Assign the following properties to one of the three materials.

Density: 8.9 g/cm³, 7.8 g/cm³, 2.7 g/cm³

Good formability, high tensile strength,

low hardness, good electrical conductivity,

high toughness, good castability, high hardness, low weight.

- a) Aluminium cast alloy: 2.7 g/cm³, good formability, good castability, low weight
- b) Tempered steel: 7.8 g/cm³, high tensile strength, high toughness, high hardness
- c) Copper: 8.9 g/cm³, good formability, low hardness, good electrical conductivity

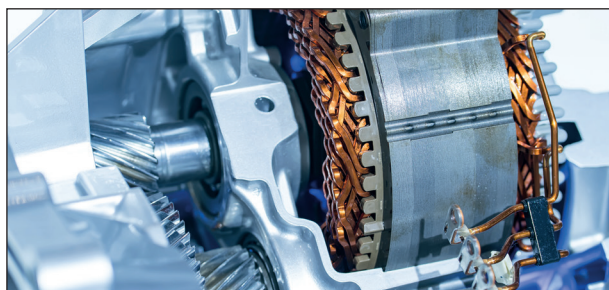

5. What corrosion protection measures must be carried out on the mentioned machine parts of the lathe?

- 1 Spindle gear box: Check and top up the oil level
- 2 Feed shaft: Lubrication
- 3 Lathe slide: Oiling
- 4 Cooling lubricant supply: Refilling cooling lubricant
- 5 Tailstock: Lubricating
- 6 Housing: Cleaning



Test unit for Mechanical engineering *mit Lösungen*

Übungseinheit zur Maschinentechnik

1. The components of the pillar drilling machine are marked with numbers in the picture.

a) Insert the correct number from the picture for the names of the components in the circles:

- | | |
|-----------------|--------------------|
| 10 belt drive | 4 drill spindle |
| 3 control panel | 7 table crank |
| 5 machine base | 8 feed lever |
| 9 drive motor | 2 emergency switch |
| 6 gear rack | 1 gear box |

b) Specify the corresponding components of the pillar drilling machine for the functional units:

Drive unit drive motor
 Feed unit feed lever
 Work unit drill spindle
 Transmission unit belt drive, gear box
 Control unit control panel, emergency switch

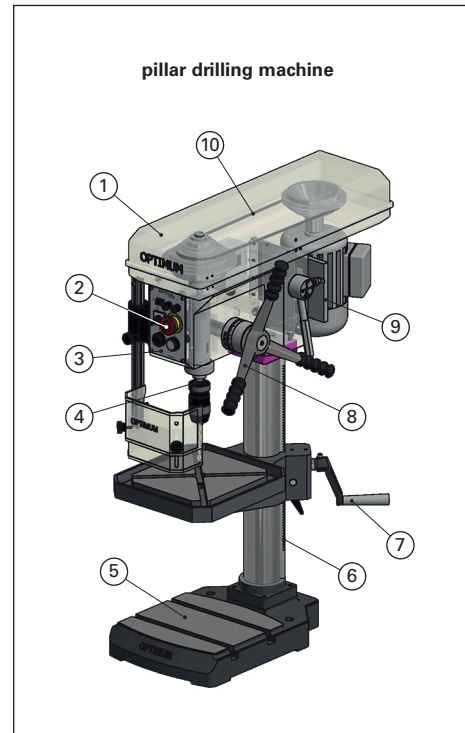

2. 10-minutes quiz to check your knowledge about gears, bearings, seals and shaft-hub connections:

a) The adjacent figure shows a worm gear. Which shaft-hub connection is used at the output shaft?

feather key connection

b) Specify another shaft-hub connection for the transmission of high torques.

spline shaft connection

c) There are ball bearings on the drive shafts.

Why must each gear shaft be guided by two bearings?

On the output shaft there is a greater torque

d) The drive speed of the worm shaft is $n_1 = 1200 \text{ min}^{-1}$. The number of teeth of the worm shaft is given with $z_1 = 3$. The worm wheel has a number of teeth $z_2 = 80$. Which rotation speed has the worm wheel?

$$n_1 \cdot z_1 = n_2 \cdot z_2$$

$$n_2 = \frac{n_1 \cdot z_1}{z_2} = \frac{1200 \text{ min}^{-1} \cdot 3}{80} = 45 \text{ min}^{-1}$$

e) Seals in the covers and shaft feedthroughs of the worm gear prevent lubrication oil from escaping.

Enter the name of the seal and cross out the wrong information of the seal.

- | | |
|-----------------------|--------------------------|
| 1 a flat seal | is a static/dynamic seal |
| 2 a O-ring seal | is a static/dynamic seal |
| 3 a rotary shaft seal | is a static/dynamic seal |

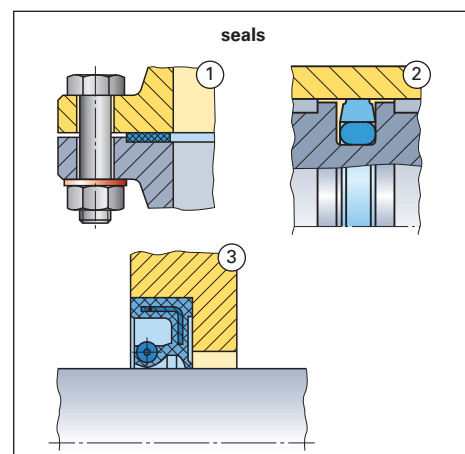
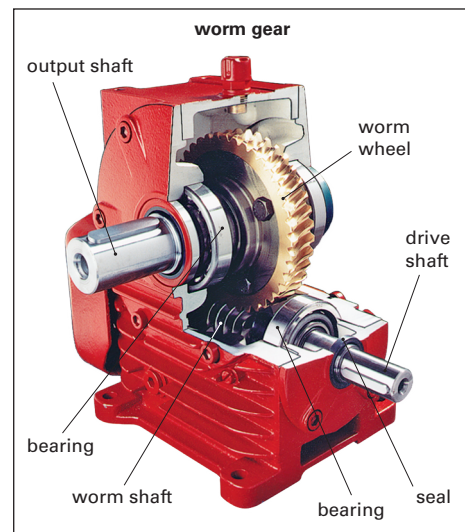

Test unit for Electrical engineering *mit Lösungen*

Übungseinheit zur Elektrotechnik

1. The electric circuit in the picture beside has several electrical components.

- ① lines ② resistors ③ switches
 ④ Amperemeter ⑤ batteries
 ⑥ electric loads ⑦ Voltmeters

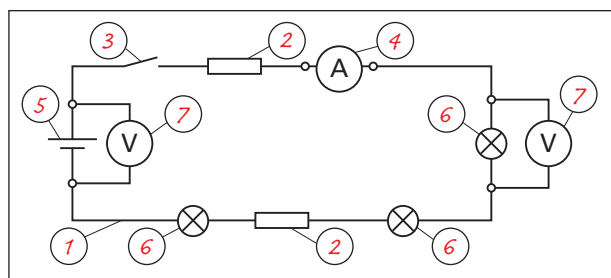

Assign the suitable component number to the components in the picture of the circuit.

2. The Copper-winding of an electric resistor has a length of 82 meters. The cross-sectional area of the winding wire is 2 mm^2 . Its specific electric resistance is: $\rho_{el} = 0.0179 \Omega \text{ mm}^2/\text{m}$

What is the electric resistance of the resistor?

$$\text{Solution: } R_c = \frac{\rho_{el} \cdot l}{A} = \frac{0.0179 \Omega \cdot \text{mm}^2/\text{m} \cdot 82 \text{ m}}{2 \text{ mm}^2} = 0.7339 \Omega$$

3. Two resistors are connected in an electric circuit by parallel circuit (picture beside). The voltage is 24 V.

One resistor has an electric resistance of 5Ω , the other resistor has 8Ω .

- Determine the total resistance of the circuit.
- What is the current rating I_{ges} in the main line?

Solution:

$$a) R = \frac{1}{\frac{1}{R_1} + \frac{1}{R_2}} = \frac{1}{\frac{1}{5 \Omega} + \frac{1}{8 \Omega}} = \frac{1 \Omega}{0.2 + 0.125} \approx 3.08 \Omega$$

$$b) I = \frac{E}{R} = \frac{24 \text{ V}}{3.08 \Omega} = \frac{24 \text{ V}}{3.08 \text{ V/A}} \approx 7.8 \text{ A}$$

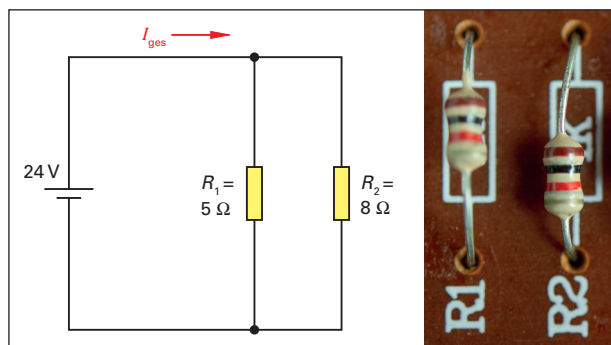

4. The electric meter shows the values of electric work of a hardening furnace.

- What electric work W does the hardening furnace draw of the electric net from 7:30 until 18:00?
- What are the daily electric costs of the hardening furnace?

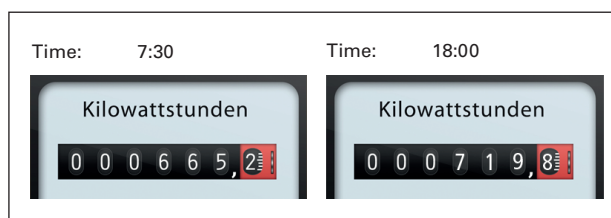

The electric readings at the beginning and the end of the working day you take from the shown electric meter. The cost per kWh will be charged by the supplier with 0.22 €/kWh .

Solution:

$$a) W = 719.8 \text{ kWh} - 665.2 \text{ kWh} = 54.6 \text{ kWh}$$

$$b) \text{Costs} = W \cdot t \cdot ET = 54.6 \text{ kWh} \cdot 10.5 \text{ h} \cdot 0.22 \text{ €/h} \approx 126.13 \text{ €}$$

5. Which electric devices are shown in the panel beside?

- a) emergency stop b) automatic cutout
 c) socket outlet d) plug
 e) electric meter f) fuse



6. A colleague feels a slight electric shock when touching an electric device. What must he do?

1. He has to release the device quickly.
2. He has to switch off the device and the automatic cutout.
3. He has to arrange the repair of the device.

7. Which electric protection measures or protection devices are shown in the picture beside?

- a) Earthing of a machine.
 b) Protective contact socket and three-core cable.
 c) Fault current interruptor.

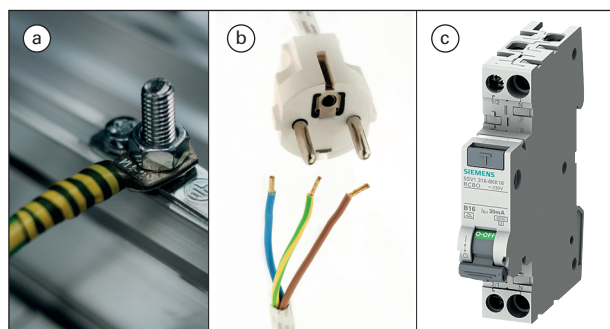

Test unit for Technical communication *mit Lösungen*

Übungseinheit zur Technischen Kommunikation

1. In the right figure you can see a three dimensional volume model for the clamping device, created by CAD-Software. The clamping device consists of standard parts such as screws or nuts and self-made components.

In the three dimensional volume model you can see only the self-made components have got with the position numbers: baseplate, clamp lever, side angle, bracket, clamping piston, counter angle, guide plate.

All components are made of the material E295.

- a) Assign the designation to the numbers.
- b) Create a parts list with the self-made components.
- c) Different drawings can be created of the three dimensional volume model. What are the differences between the general arrangement drawing and the components drawing.

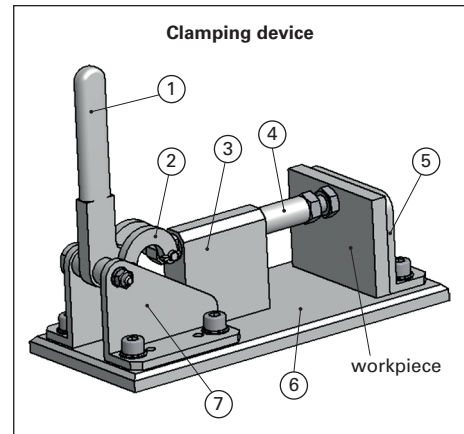

Solution:

a) Part list of the clamping device

<i>pos.</i>	<i>quantity</i>	<i>designation</i>	<i>material, standard</i>
<i>1</i>	<i>1</i>	<i>clamp lever</i>	<i>E295</i>
<i>2</i>	<i>2</i>	<i>bracket</i>	<i>E295</i>
<i>3</i>	<i>1</i>	<i>guide plate</i>	<i>E295</i>
<i>4</i>	<i>1</i>	<i>clamp piston</i>	<i>E295</i>
<i>5</i>	<i>1</i>	<i>counter angle</i>	<i>E295</i>
<i>6</i>	<i>1</i>	<i>baseplate</i>	<i>E295</i>
<i>7</i>	<i>2</i>	<i>side angle</i>	<i>E295</i>

b) In the arrangement drawing the entire device is shown. The components are labelled with position numbers.

The component drawing shows one component with its dimensions.

2. The self-made components for 100 clamping devices were manufactured in the workshop.

During the production there were problems with the assembly, because 80 components of the 700 different components were manufactured incorrectly.

To get an overview, the proportion of the defective components was entered in a pie chart. See on the right.

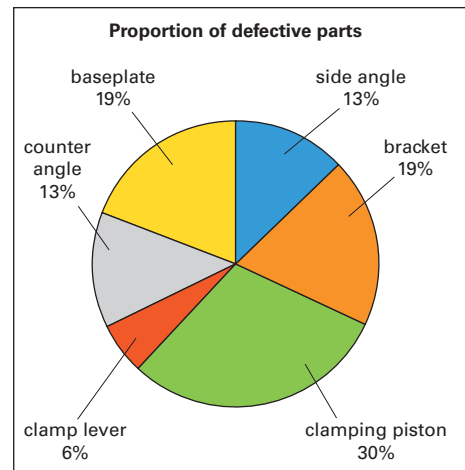

- a) The management wants to see in a bar chart, how many components were defective. With using the information of the pie chart besides, draw a bar chart with the numbers of defective components.
- b) Explain, why a bar chart is more suitable than a line chart for showing the number of defective components.

Solution:

a) *Bar chart with the number of the defective components*

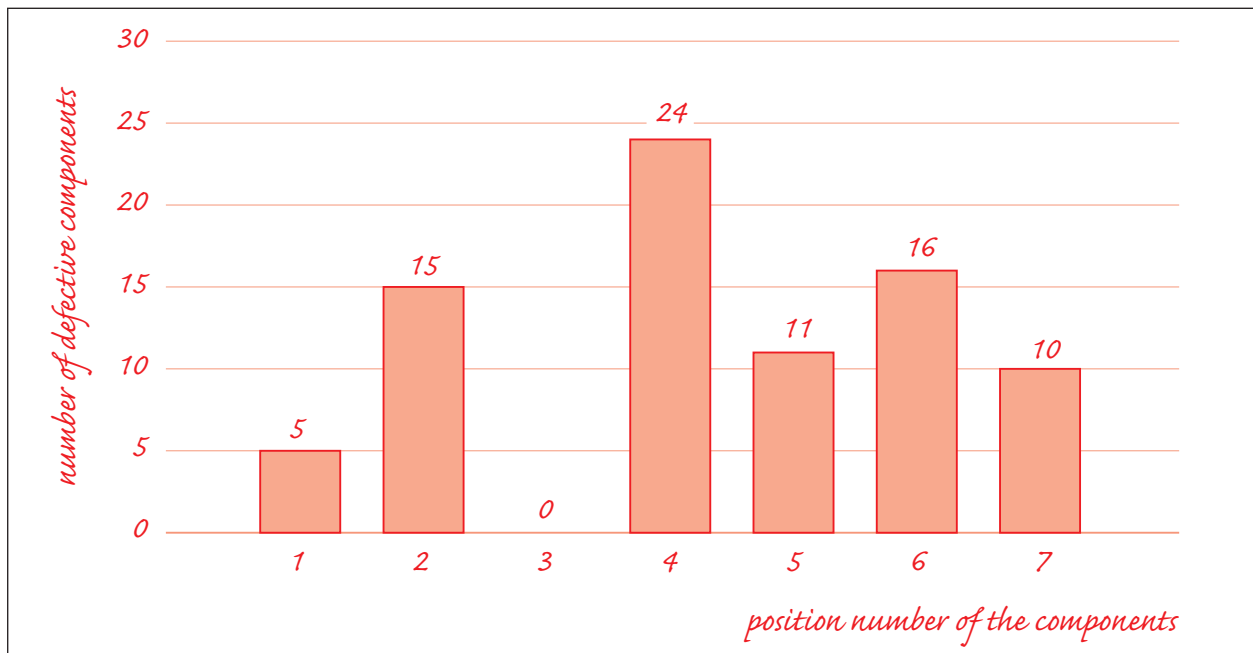

b) *With a bar chart the measured values can be compared better. This is possible, for example, when comparing different defective components.*

With a line chart, the course of several parameters can be shown better.